

HONORING THE PAST.  
PLANNING FOR THE  
FUTURE.

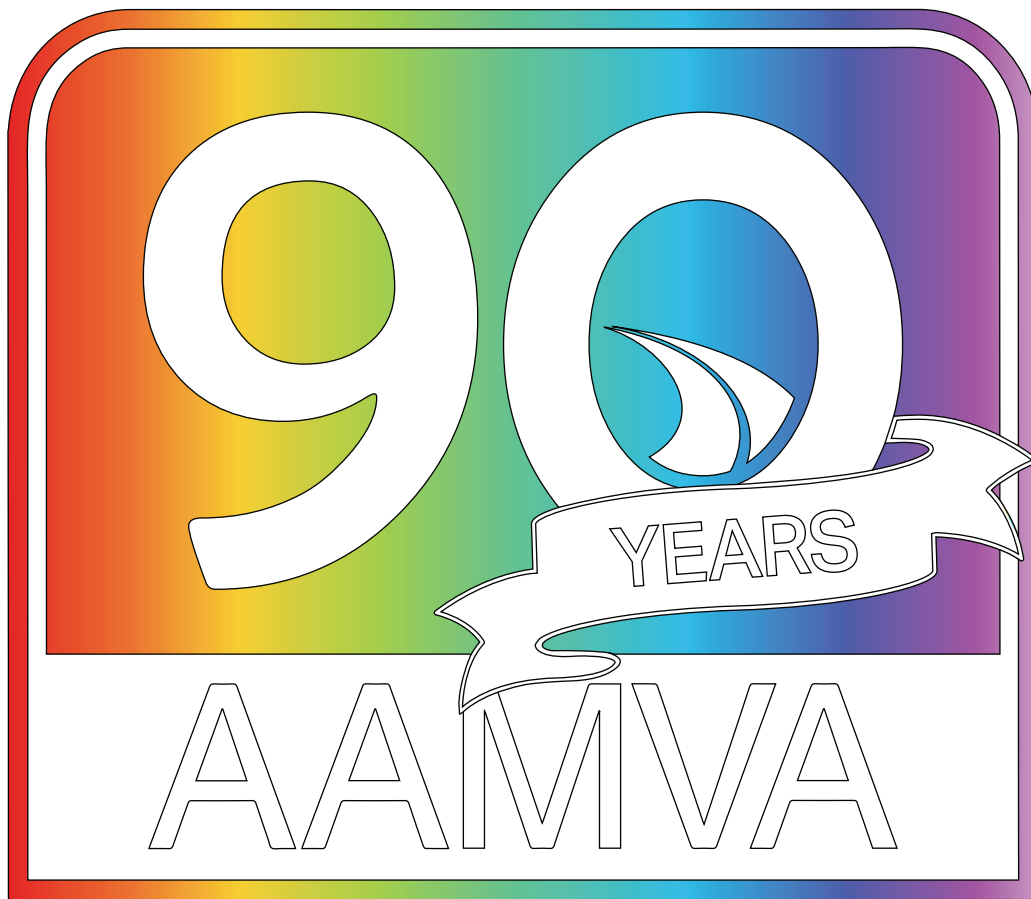

**COLORING BOOK**

Celebrating 90 years of **Safe Drivers, Safe Vehicles, Secure Identities, and Saving Lives!**

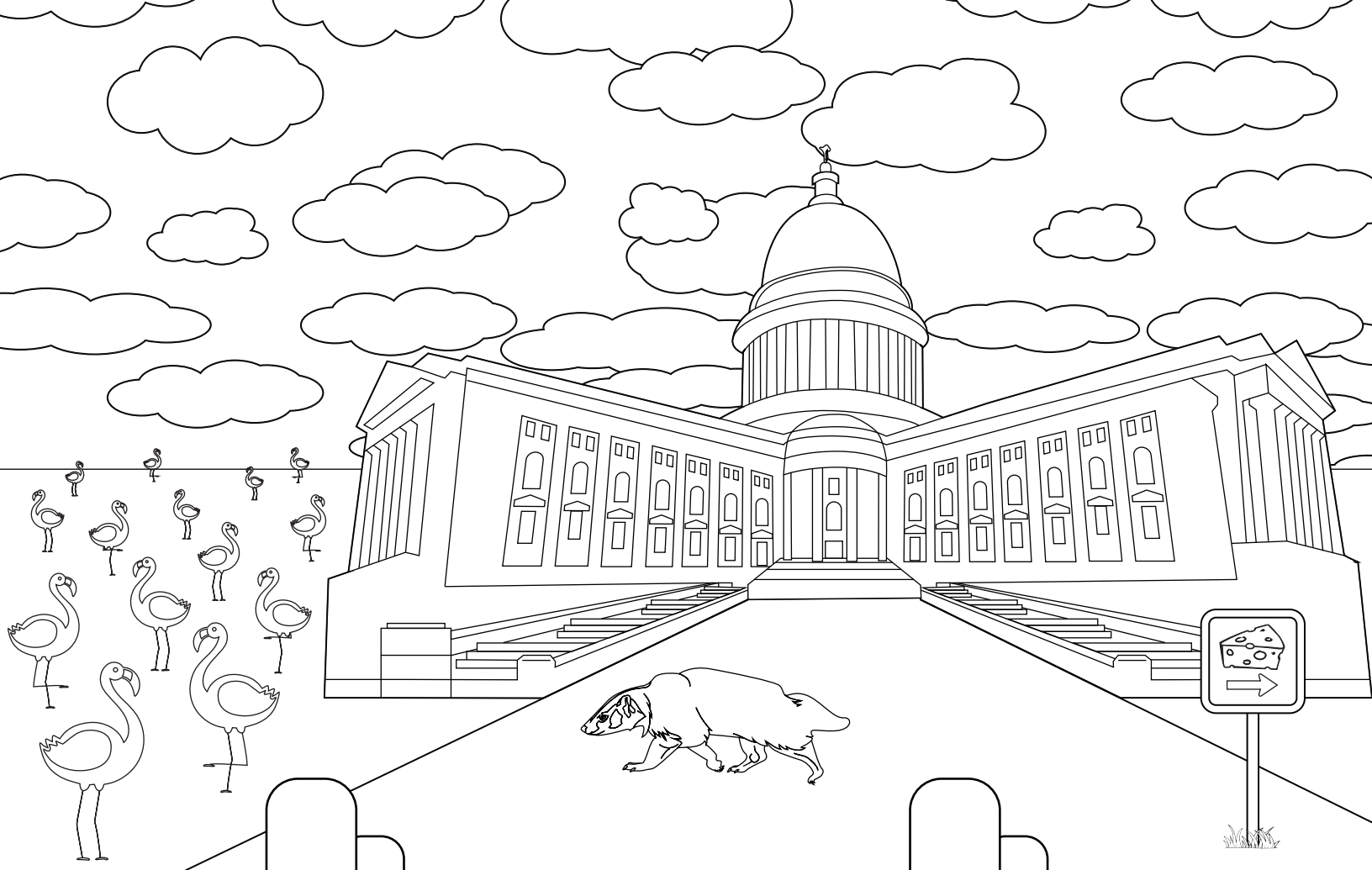

INDUSTRY

RECREATION

WISCONSIN

WELCOMES

YOU

AGRICULTURE



**WELCOME** TO  
AAMVA'S ANNUAL INTERNATIONAL  
CONFERENCE IN MADISON,  
WI!

THIS  
YEAR WE ARE CELEBRATING  
OUR 90TH ANNIVERSARY. TO GET  
STARTED ON OUR JOURNEY, WE HAVE  
TO GO BACK TO THE YEAR  
1933...

***AAMVA WAS FOUNDED  
IN 1933.***

COL. E. AUSTIN BAUGHMAN, COMMISSIONER  
OF MOTOR VEHICLES IN MARYLAND, WAS  
ELECTED AAMVA'S FIRST PRESIDENT.

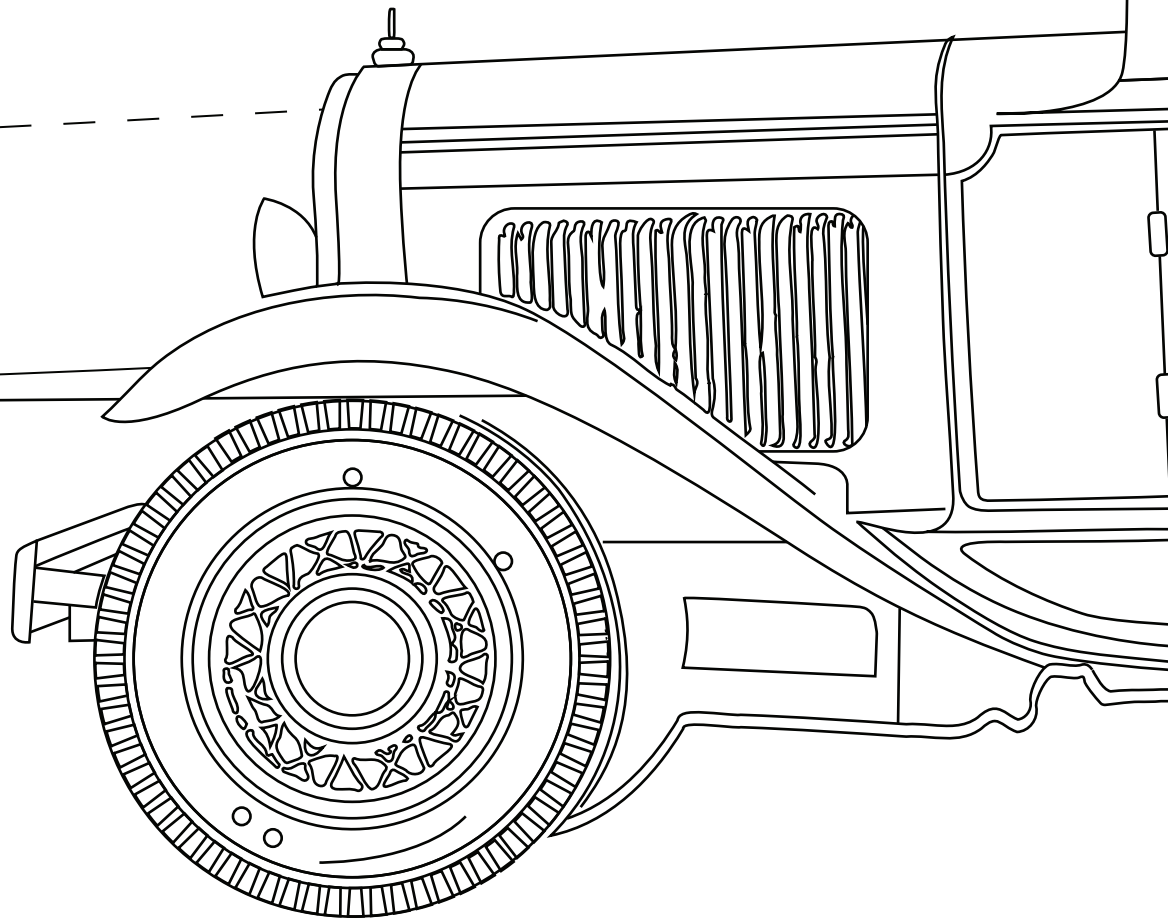

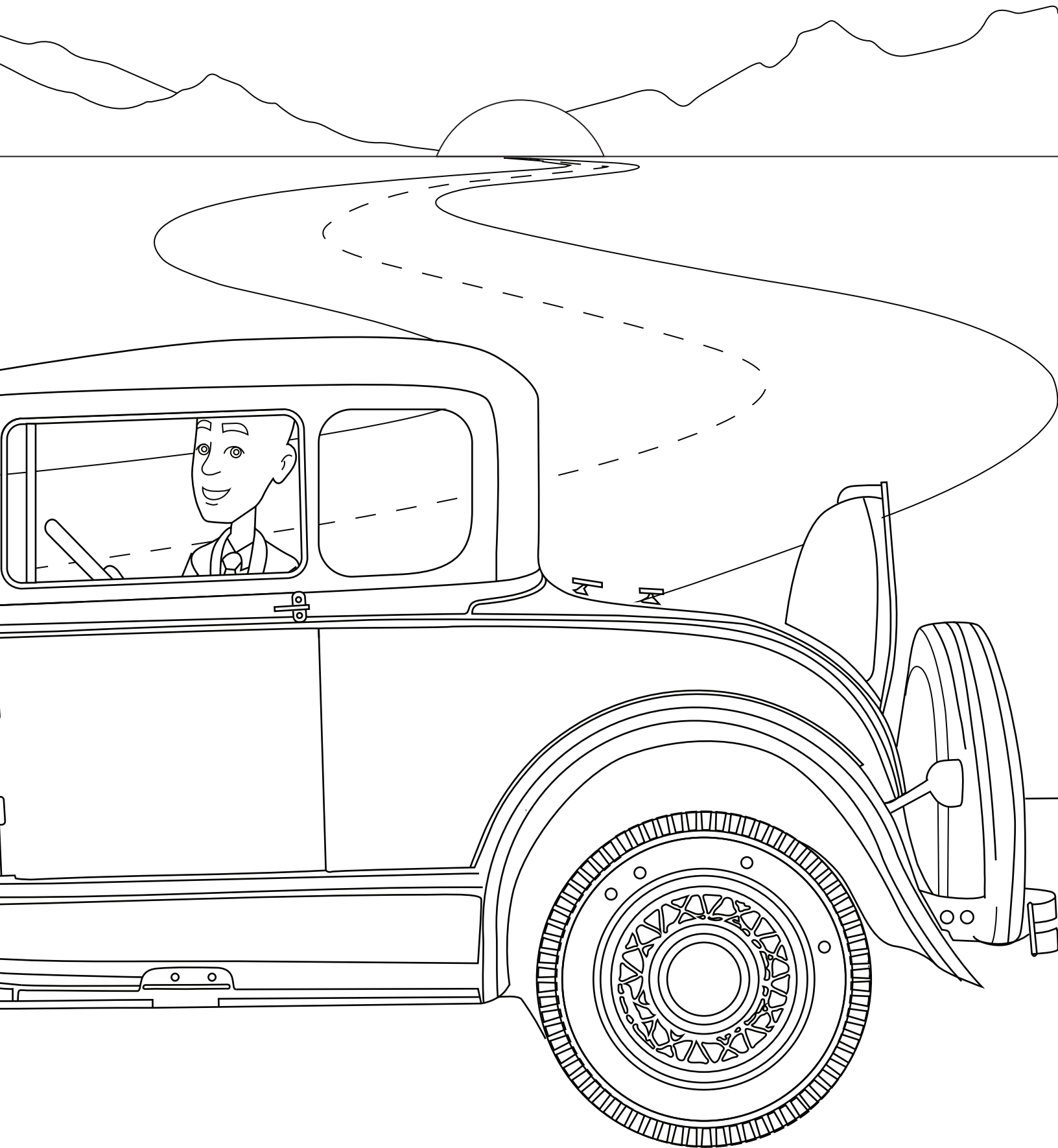

So...how did we get to where we are now?

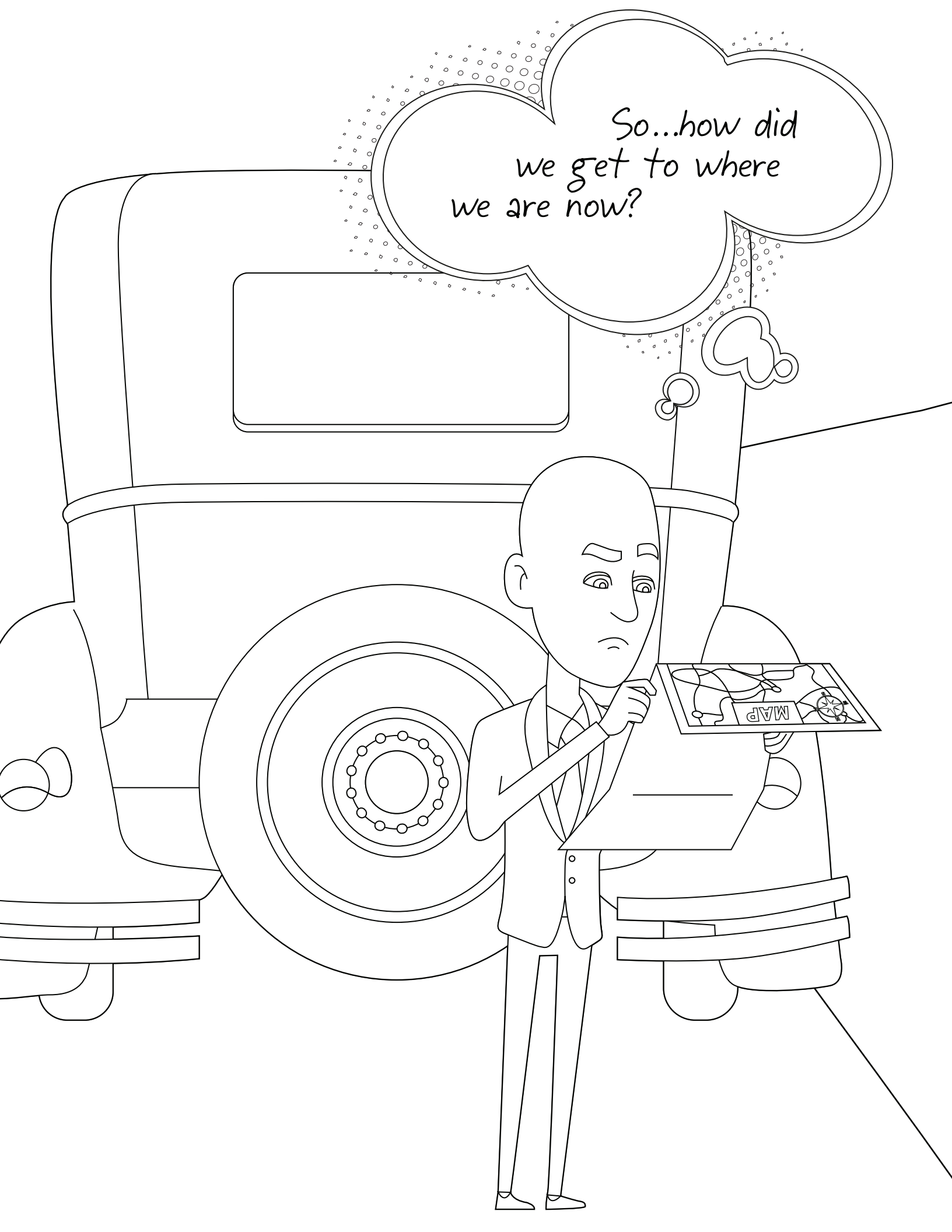

A black and white line drawing of a winding road with a dashed center line. The road curves from the top right towards the bottom left, leading to a signpost. The signpost has two vertical posts and a large rectangular sign with rounded corners. The text on the sign is centered and reads: "AFTER AN EXCITING JOURNEY OF TWISTS & TURNS WE BECAME THE ORGANIZATION YOU KNOW TODAY!".

AFTER AN EXCITING JOURNEY OF

***TWISTS & TURNS***

WE BECAME THE ORGANIZATION YOU KNOW  
TODAY!

# START

AAMVA was founded. Colonel E. Austin Baughman, commissioner of motor vehicles in Maryland, was elected the first president.

1933

1938

The original basic standards for driver licensing work were developed.

All U.S. states require driver's licenses.

1954

AAMVA launched its award-winning magazine, MOVE Magazine.

1996

PDPS was deployed to provide a central repository of information on individual driving privileges.

1994

1992

The Anti-Car Theft Act was passed, forming a legislative mandate for the creation of NMVTIS.

1999

Electronic Driver status exchange between the U.S. and Canadian jurisdictions was established.

2001

After the attacks of 9/11, AAMVA shifted its focus to the security of licensing.

1989

AAMVA created AAMVAnet to build the first network to track commercial driver histories.

AAMVA

90





**1956**

The size of license plates became standardized.

**1960**

The Driver License Compact was formed.

**1959**

All U.S. States required exams before issuing driver's licenses.

**1972**

Prince Edward Island became the first Canadian province to issue photo licenses.

**1986**

The Commercial Motor Vehicle Safety Act was passed, requiring CDLIS.

**1981**

NHTSA began requiring all vehicles to have a standard 17-character VIN.

WORK IN PROGRESS

**2005**

The REAL ID Act was passed and the first international standard for driver's licenses was published.

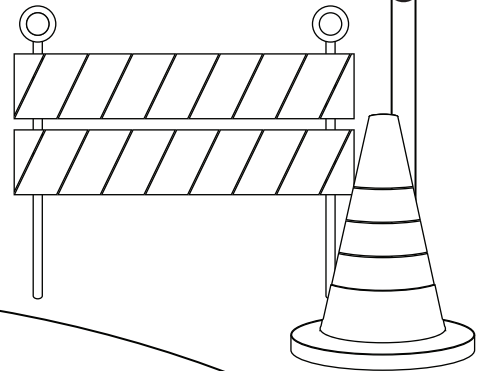
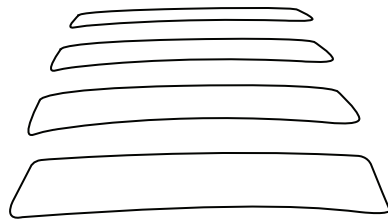
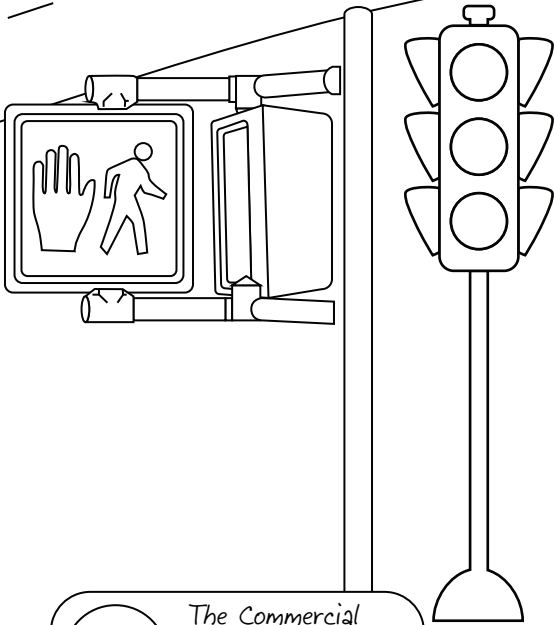

S2S was developed and Wisconsin became the first state to implement it.

**2015**

**2016**

AAMVA amended its bylaws to provide a dedicated seat for Canadian representation on the Board of Directors.

AAMVA published the first mobile driver's license implementation guidelines.

**2019**

The inaugural class of AAMVA's Leadership Academy was held.

**2014**

AAMVA published its first guidance for the safe testing and deployment of automated vehicles.

**2018**

AAMVA launched DLDV to fight the prevalence of counterfeit DL/IDs.

**2012**

**2010**

All U.S. States were required to report to NMVTIS and use it as part of their titling application.

AAMVA amended its bylaws to include a dedicated seat for law enforcement on the Board of Directors.

**2009**

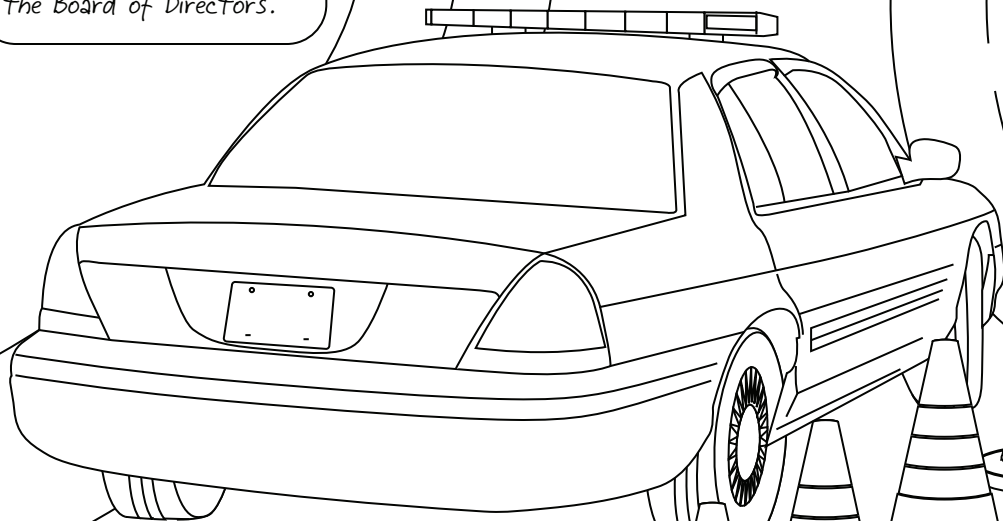

SOBRIETY CHECKPOINT AHEAD

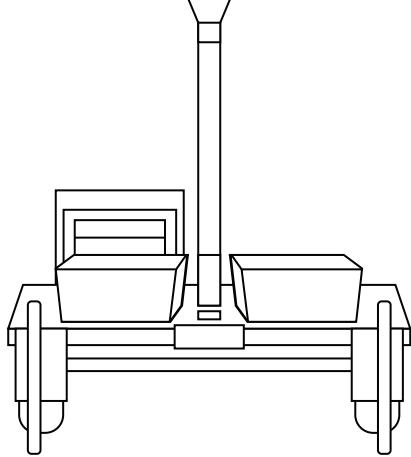
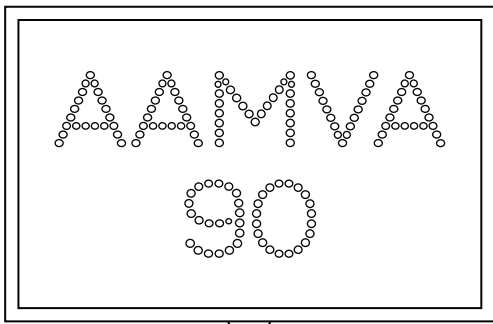

# ANNIVERSARY

**2023**

AAMVA implemented the mDL Digital Trust Service to support the exchange of encrypted keys necessary for mDL interoperability.

**2022**

S2S began to offer the Driver History Record functionality, supporting the concept of "one driver, one history record" for all drivers and NMVTIS reached full participation of all continental U.S. states.

2020

DETOUR

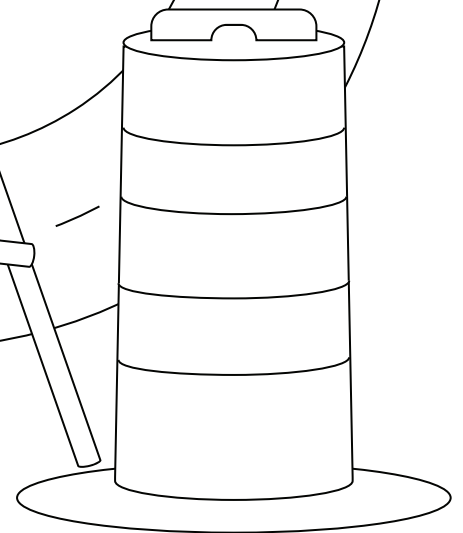
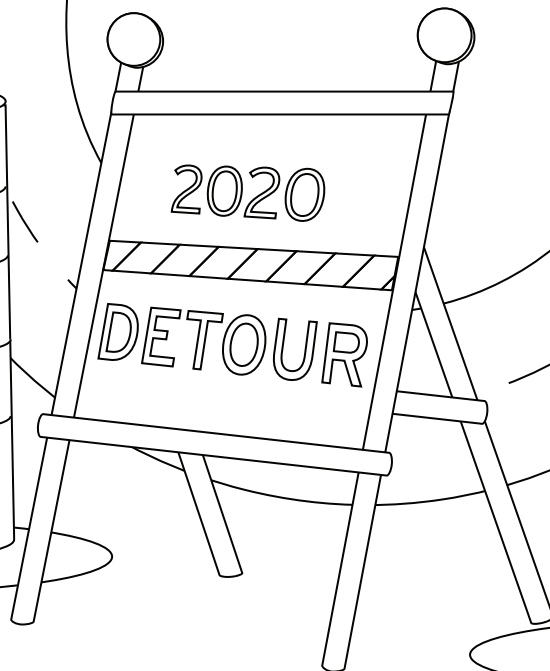
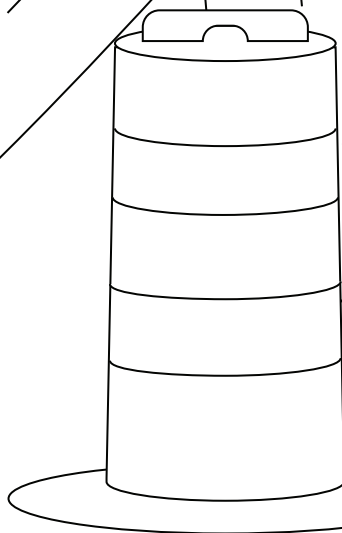

NOW, WE ARE A MULTIFACETED  
COMPANY OF OVER 200 EMPLOYEES  
SPECIALIZING IN  
DRIVERS, VEHICLES, IDENTITY,  
LAW ENFORCEMENT,  
& OPERATIONS.

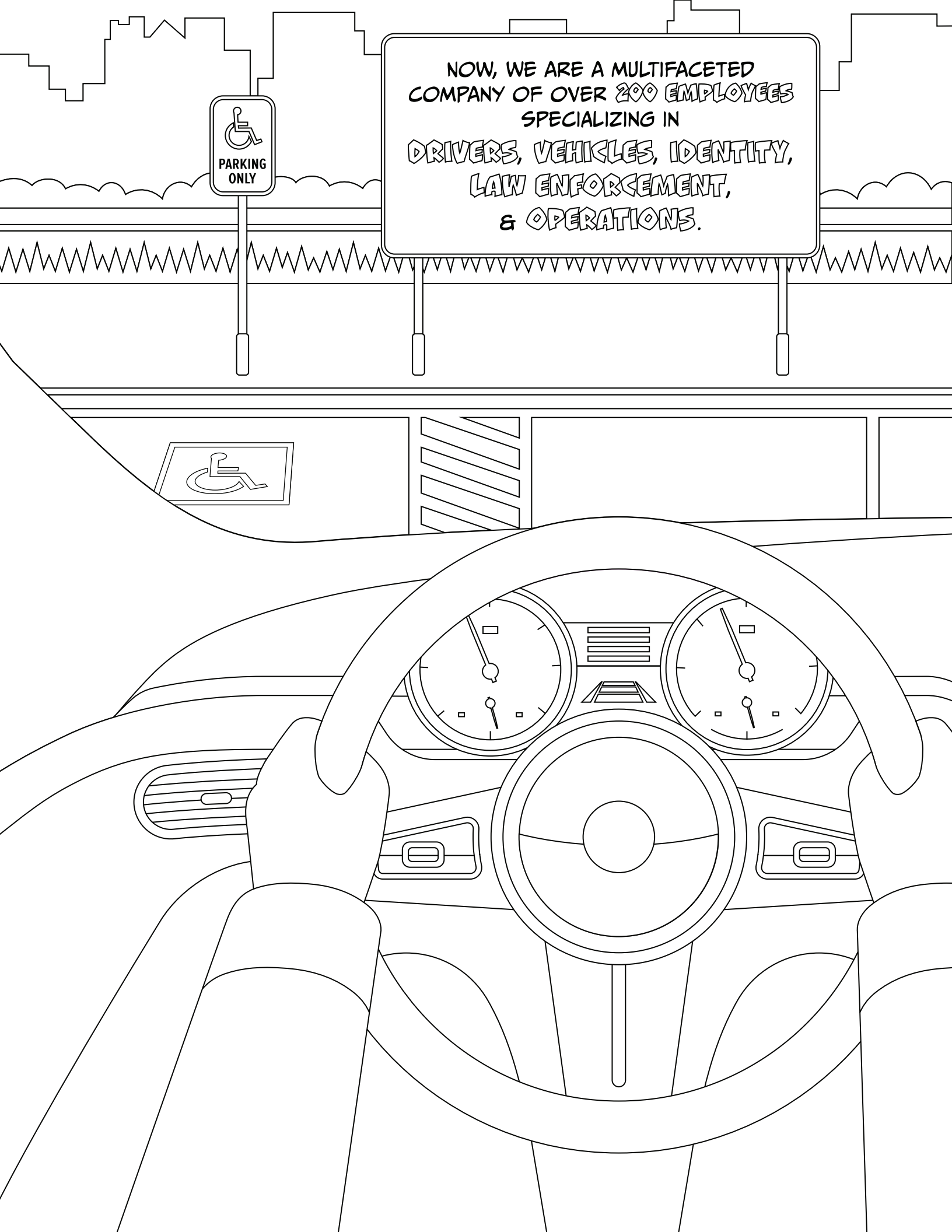

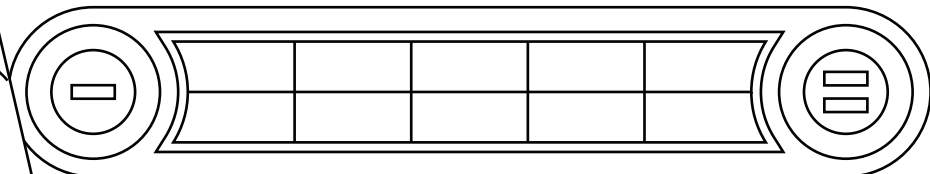
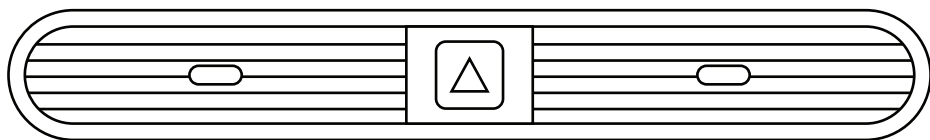
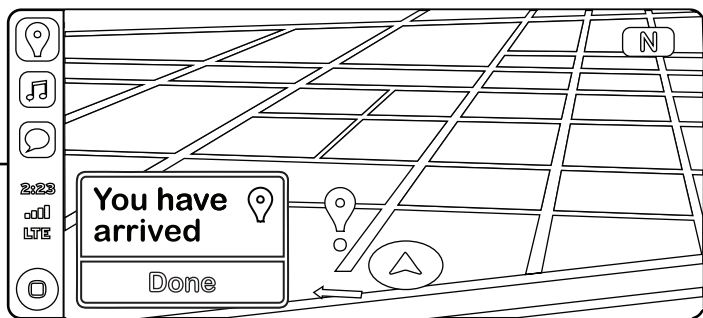
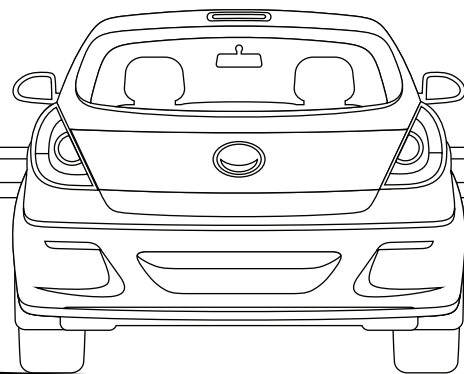
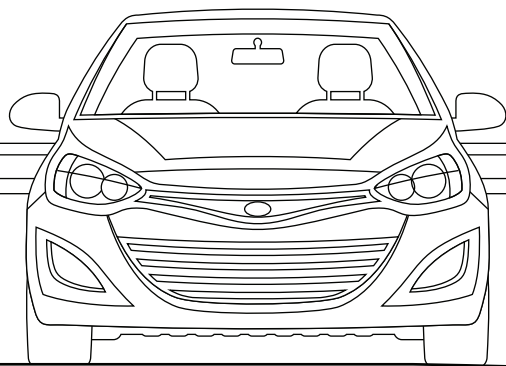
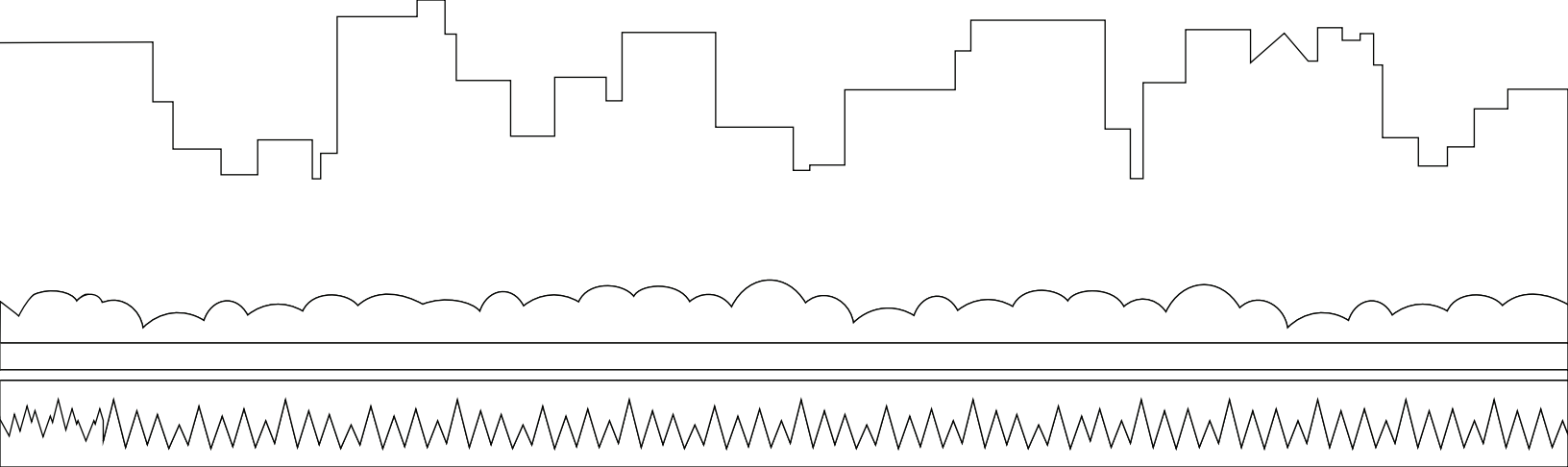

**OUR  
MEMBERS  
INCLUDE...**



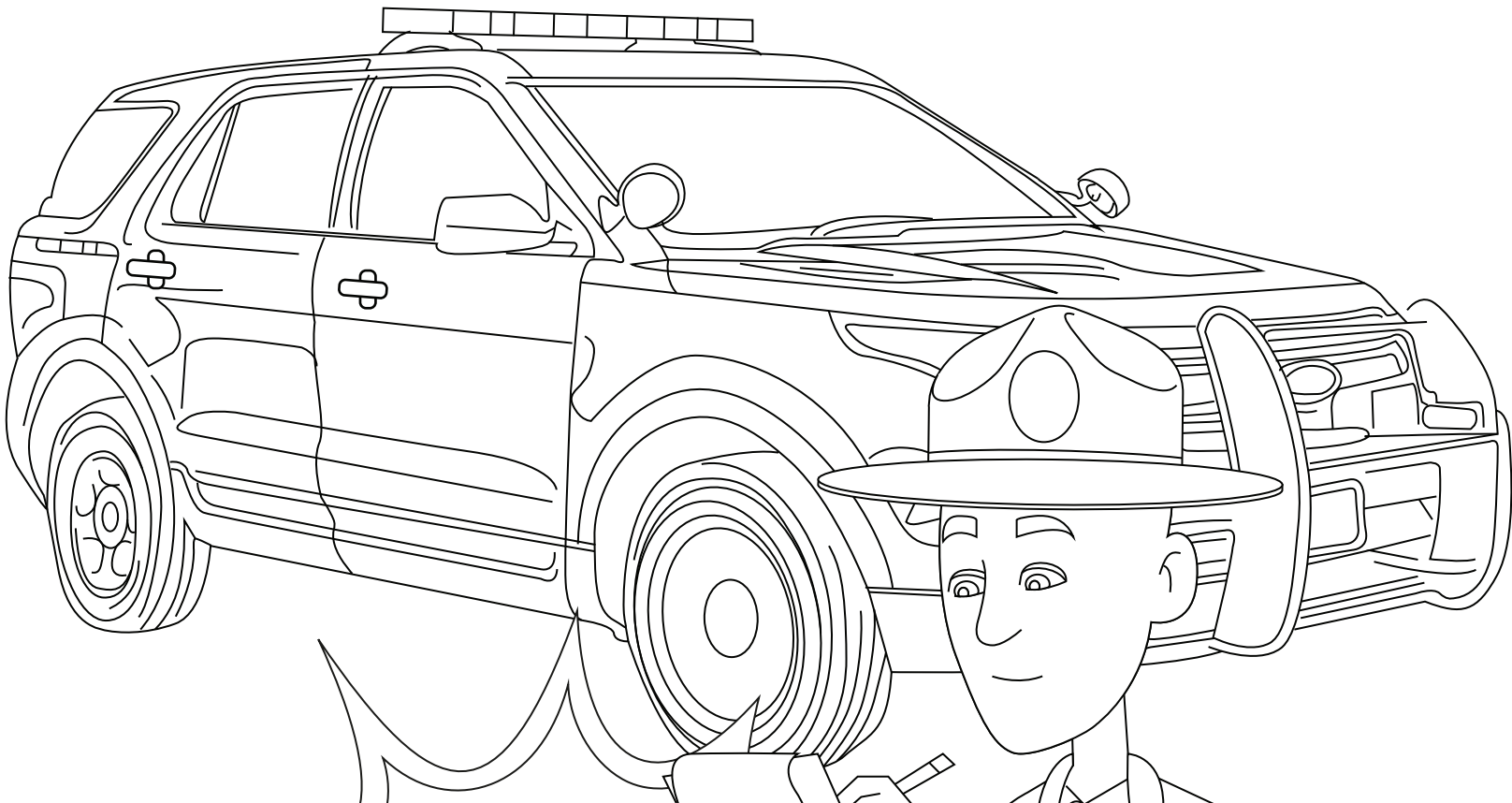

&

*Law  
Enforcement*

**PROFESSIONALS**

**AS WELL AS INDUSTRY PARTNERS,  
GOVERNMENT AGENCIES, &  
ORGANIZATIONS.**

**WE  
OFFER THEM A  
DIVERSE SELECTION  
OF RESOURCES.**

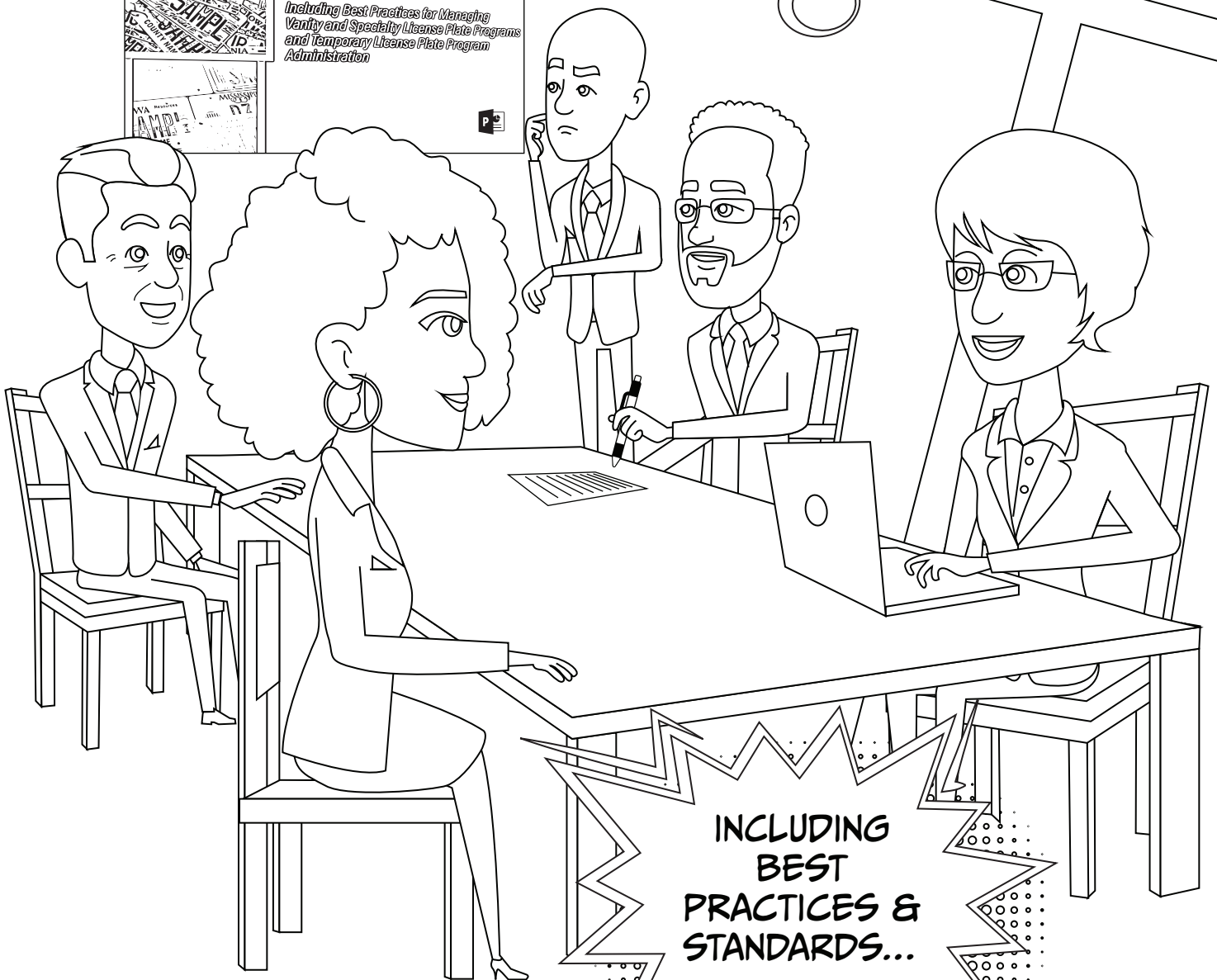
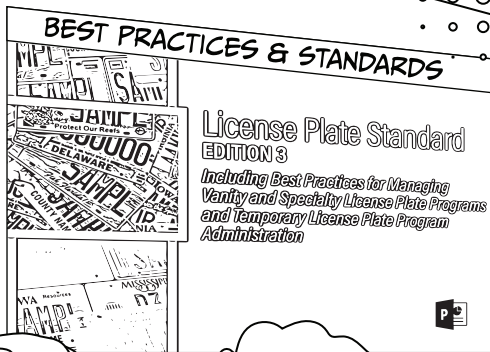

**INCLUDING  
BEST  
PRACTICES &  
STANDARDS...**



...NEWS  
&  
PUBLICATIONS...

...INTERVIEWS  
AND  
PROFILES...

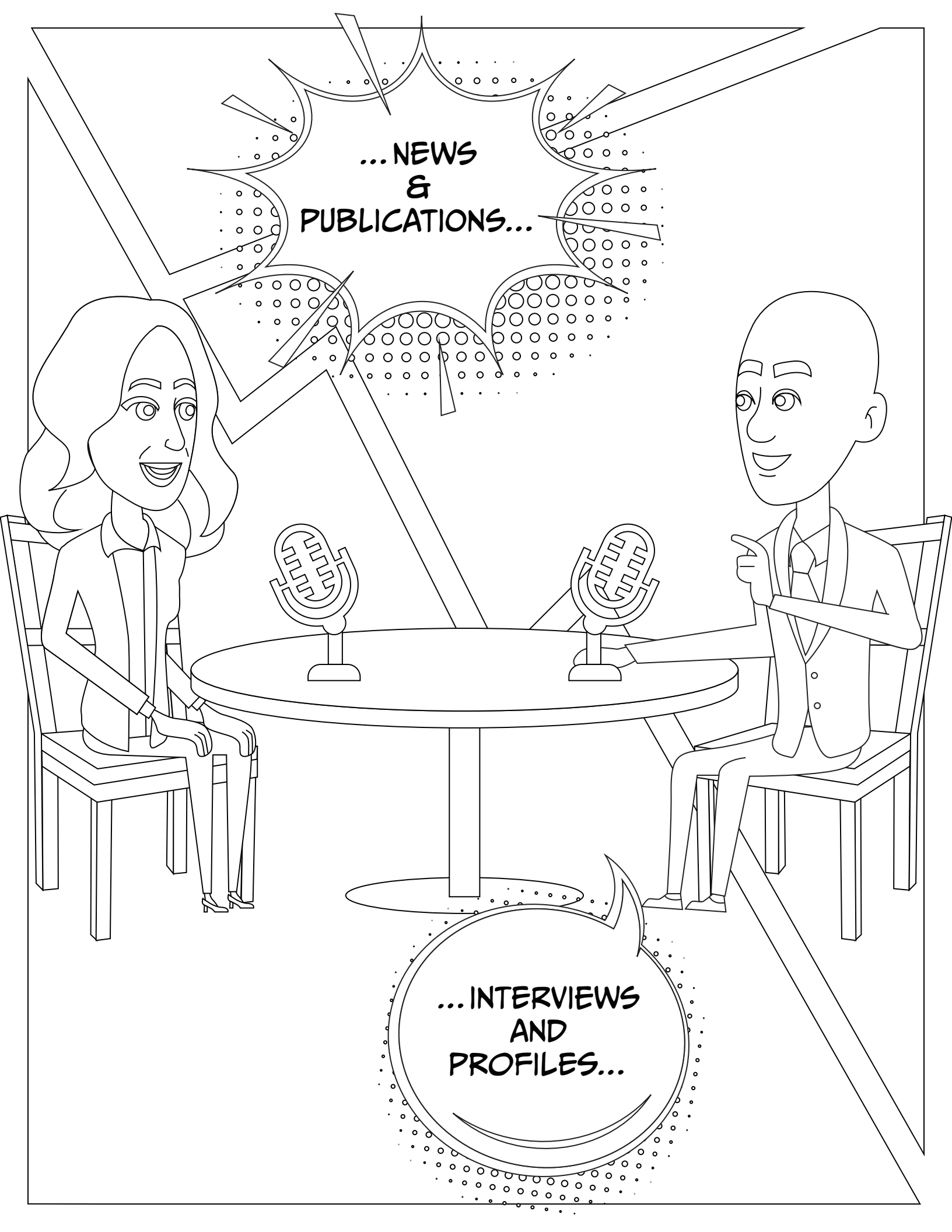

**TRAININGS**

**WORKSHOPS**

**...AND NUMEROUS  
LEARNING &  
NETWORKING  
OPPORTUNITIES.**

**WEBINARS**

**CONFERENCES**

**POP UP  
CLASSROOMS**

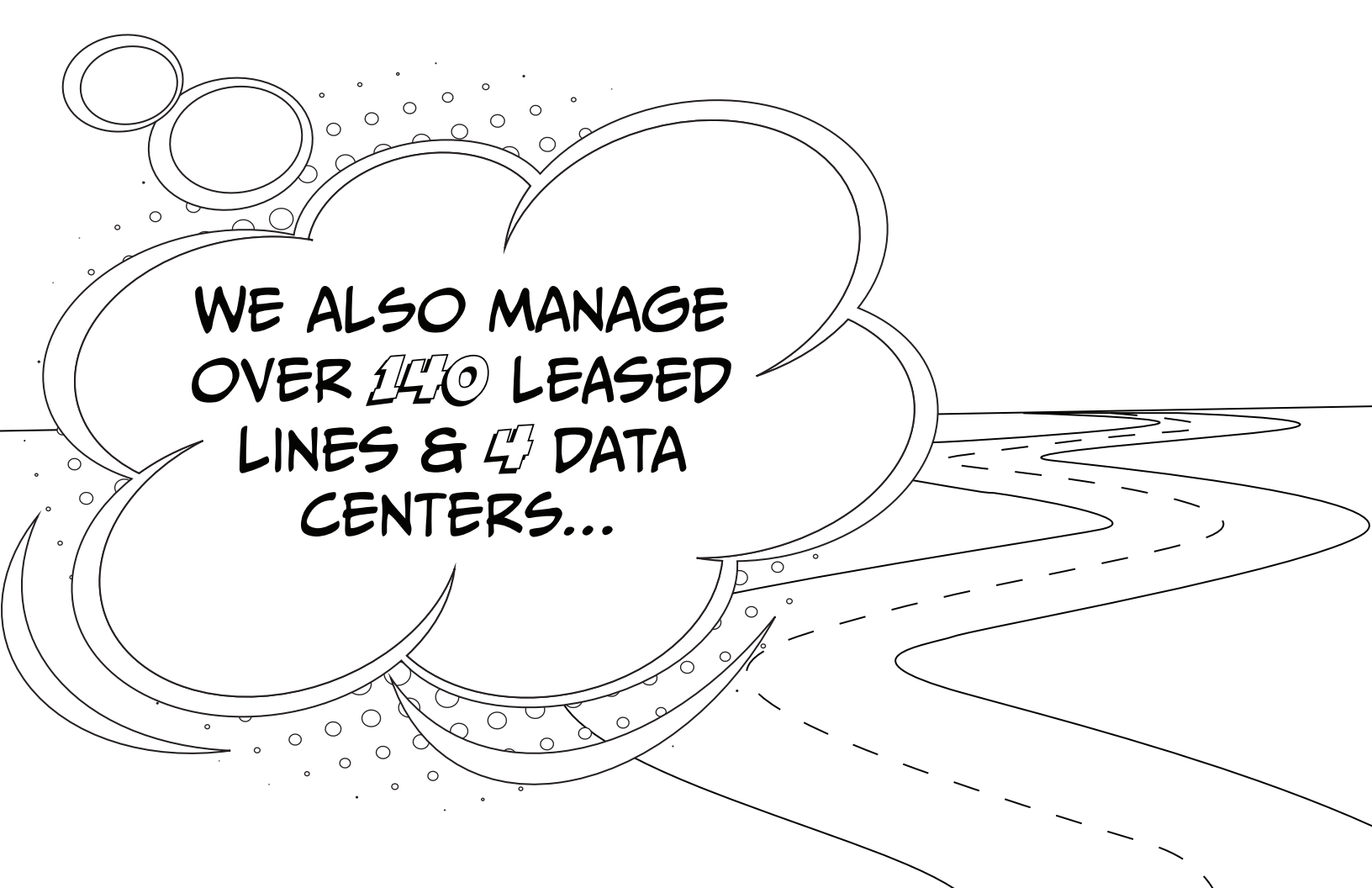

WE ALSO MANAGE  
OVER **140** LEASED  
LINES & **4** DATA  
CENTERS...

...AND HAVE **14** SYSTEMS THAT  
FACILITATE THE ELECTRONIC  
EXCHANGE OF **DRIVER, VEHICLE,**  
AND **IDENTITY** INFORMATION AND  
PROCESS MORE THAN **2.4**  
**BILLION** MESSAGES ANNUALLY!

WE HAVE *35*  
BOARDS,  
COMMITTEES, &  
WORKING GROUPS

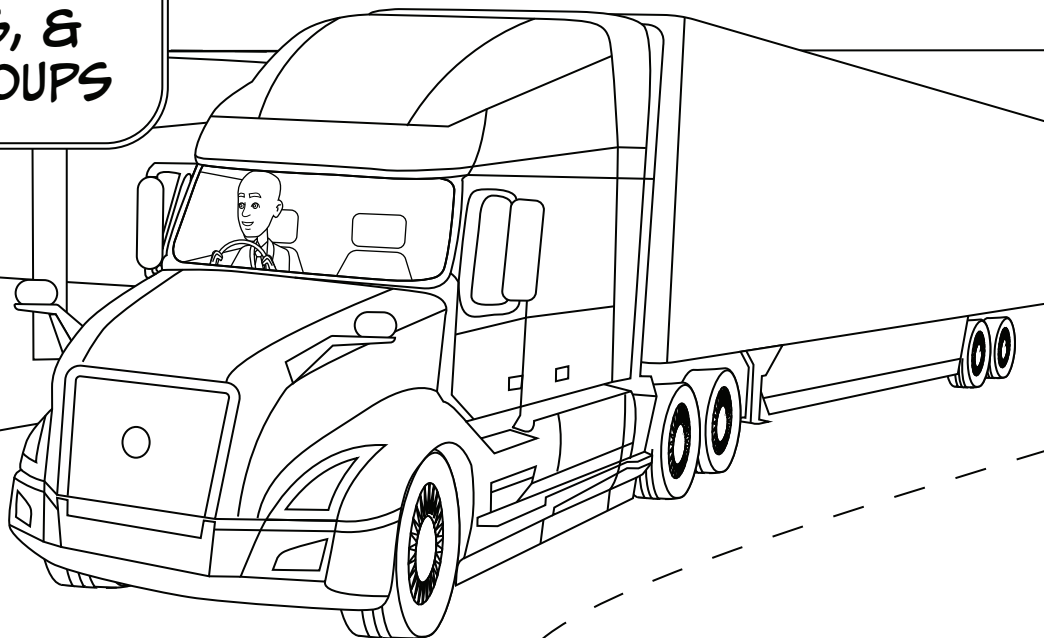

WITH *236*  
MEMBER  
VOLUNTEERS

**AND  
WE'RE  
JUST  
GETTING  
STARTED.**

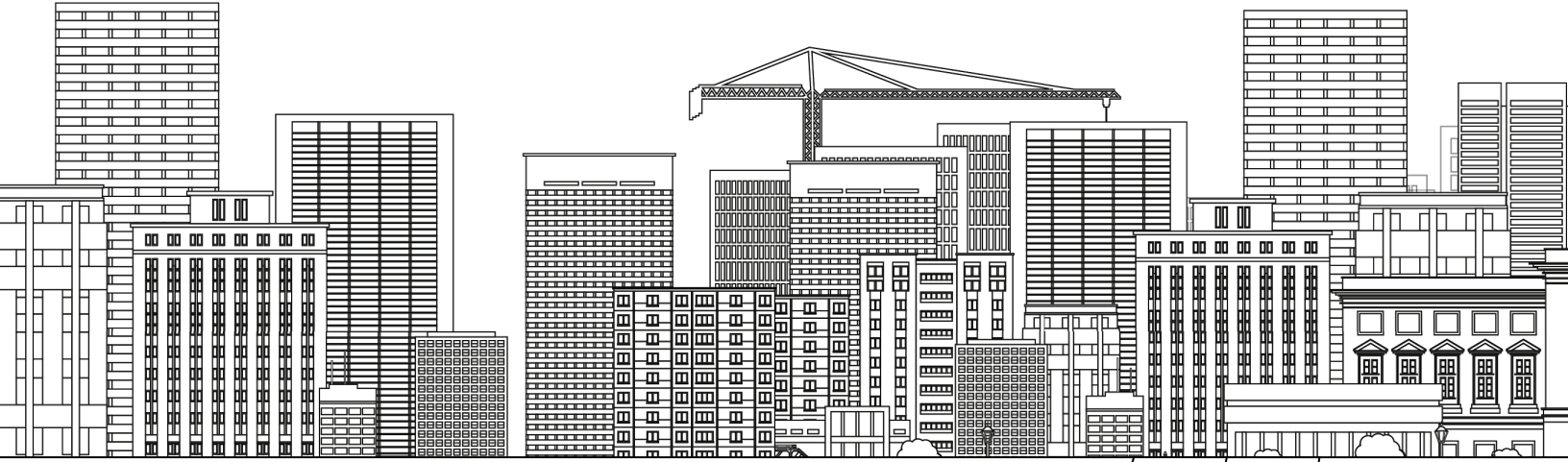

SAFE  
VEHICLES

SAFE  
DRIVERS



SECURE  
IDENTITIES

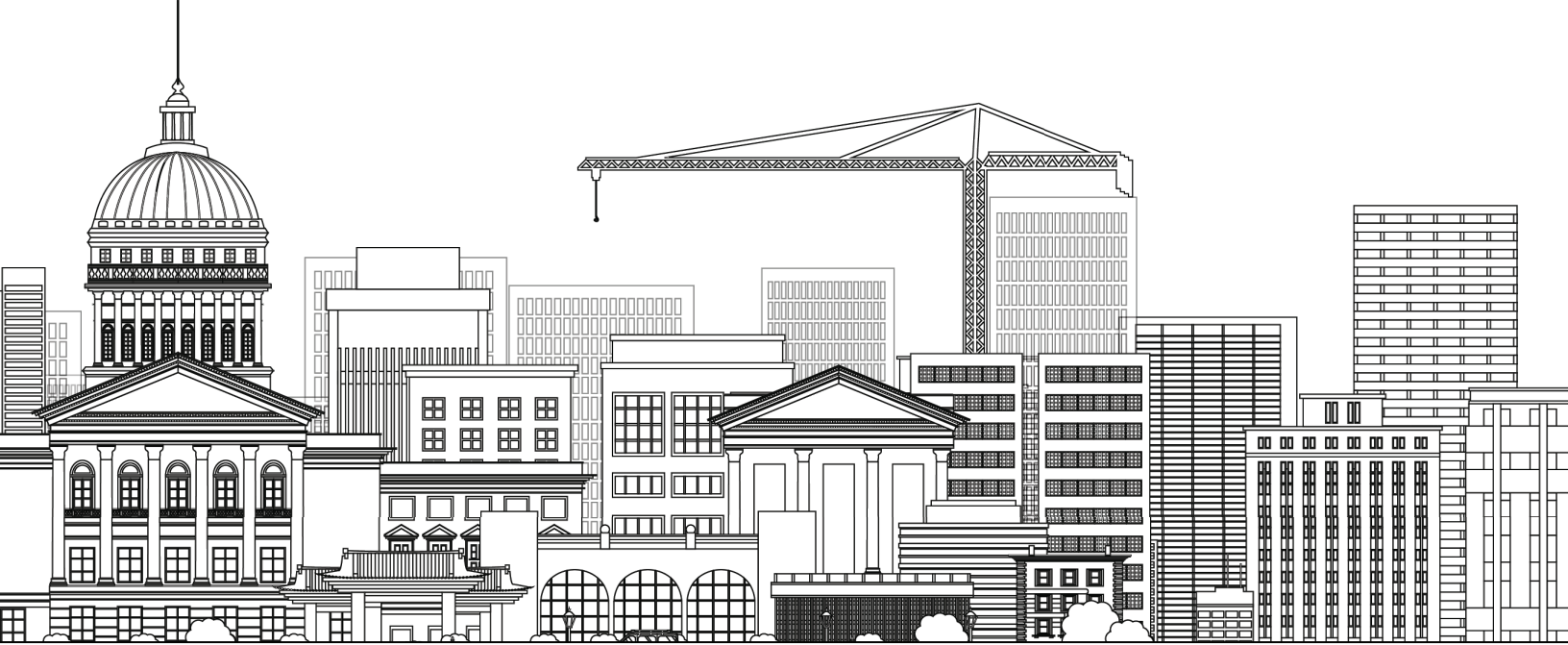

***SAVING  
LIVES***

***WITH OUR GOAL OF  
SAFE DRIVERS, SAFE  
VEHICLES, SECURE  
IDENTITIES, & SAVING  
LIVES...***

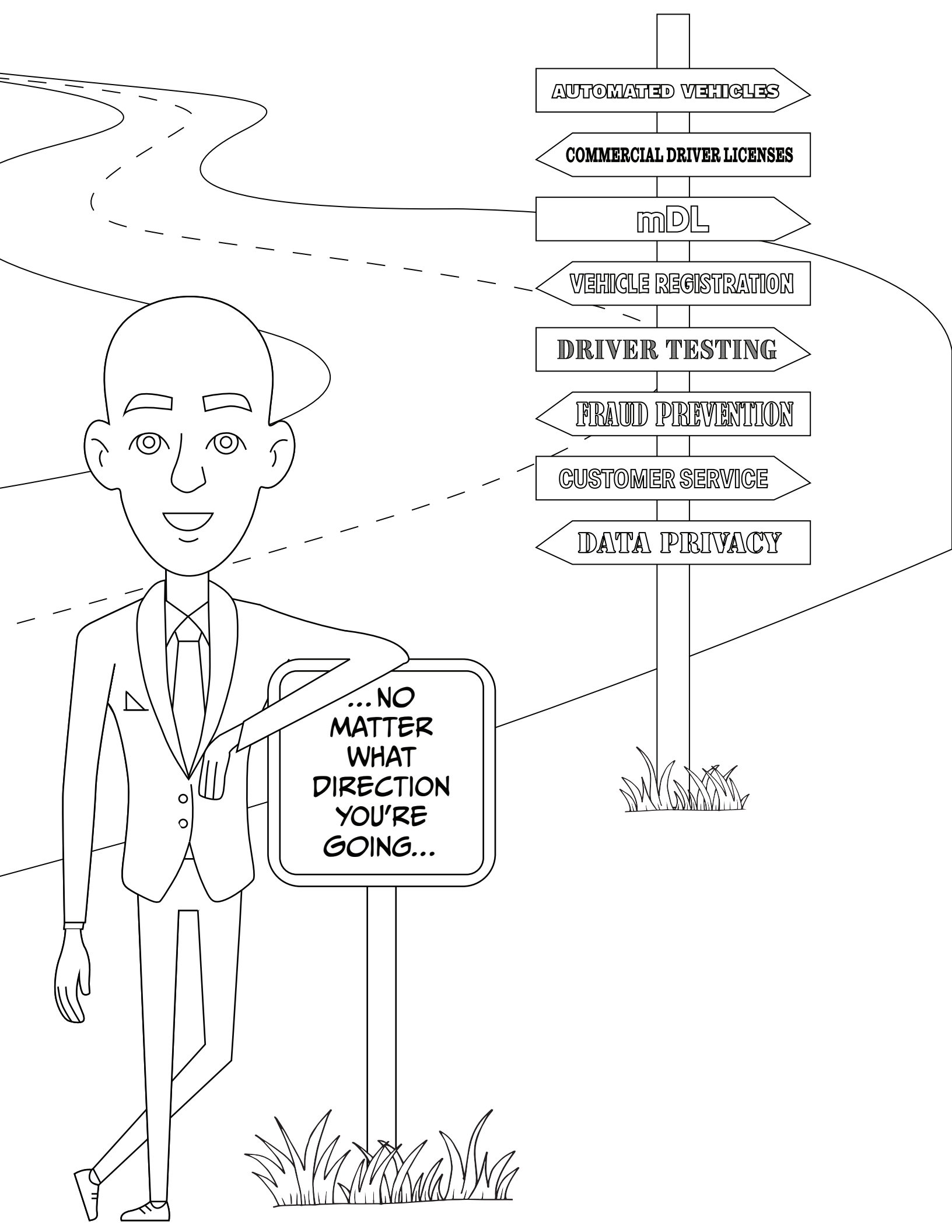

AUTOMATED VEHICLES

COMMERCIAL DRIVER LICENSES

mDL

VEHICLE REGISTRATION

DRIVER TESTING

FRAUD PREVENTION

CUSTOMER SERVICE

DATA PRIVACY

...NO  
MATTER  
WHAT  
DIRECTION  
YOU'RE  
GOING...



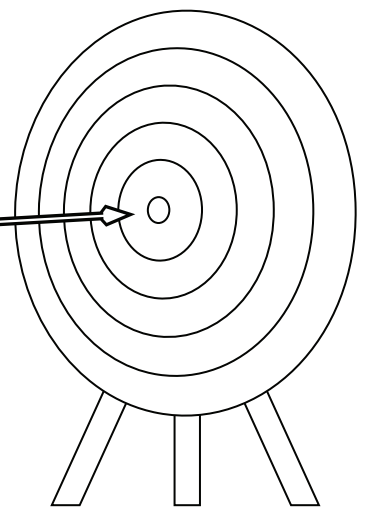



**YOUR MISSION**

IS

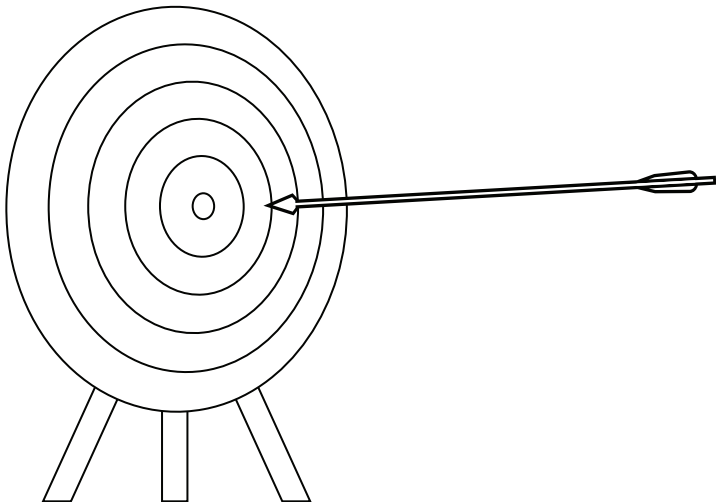
**OUR MISSION.**







HERE'S TO THE NEXT

90  
YEARS!

# AAMMVA90

*Want to color it  
again?*

SCAN THE QR CODE BELOW FOR A FREE  
DOWNLOADABLE PDF OF THIS  
COLORING BOOK.

